

Locker accessories

Sloping tops



Ideal in hygiene sensitive locations, sloping tops prevent items and litter from accumulating on locker tops.

- Makes cleaning easier.
- Choose from factory-fitted or retrofit.
- Available on all standard lockers.

Cloakroom units

Fitted between adjacent lockers, cloakroom units offer even more storage space.

- Top units incorporate a central full-length hanging rail.
- Quarto or Sixto lockers can be placed on top for additional storage space.
- Base units include a free standing rack to support footwear or other items 150mm above the floor.



Locker stands



Locker stands provide maximum access to floor space in areas where floors need frequent cleaning,

- Manufactured using 25mm square tubes.
- All locker stands come with adjustable feet.
- Available on all standard lockers.
- Stand height 150mm.

Captive coat hangers

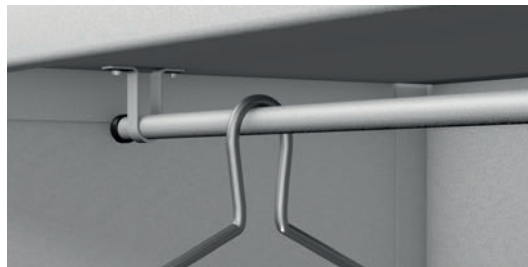

Specified at the time of order, captive coat hangers cannot be removed, preventing theft and accidental loss.

- Factory fitted.
- Available for all lockers and cloakroom units with hanging rails.

Locker stand & bench

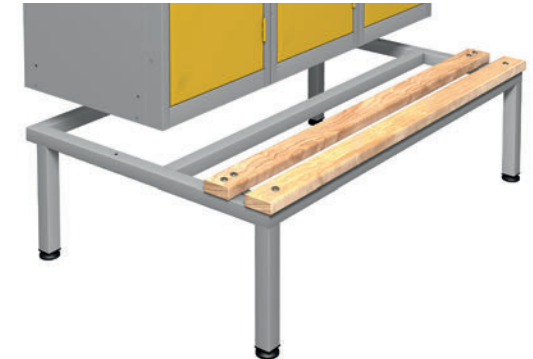

Ideal in changing rooms, lockers stands and benches provide users with secure storage whilst offering bench seating.

- Full access to the locker.
- Units come complete with adjustable feet.
- Two beech slats and metal framework form a bench seat.
- Stand height 400mm.

Numbered key fobs



Made in various coloured plastic and engraved and printed to any number and/or alpha character of your choice.