

MetaCel Fingerprint

Please make sure you read this manual, before using your safe.

De Raat
Security Products
Safes, lockers and more...

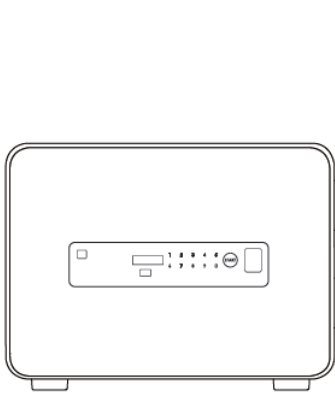

MC-20

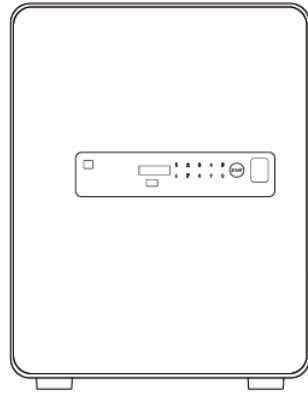

MC-40



Safe overview

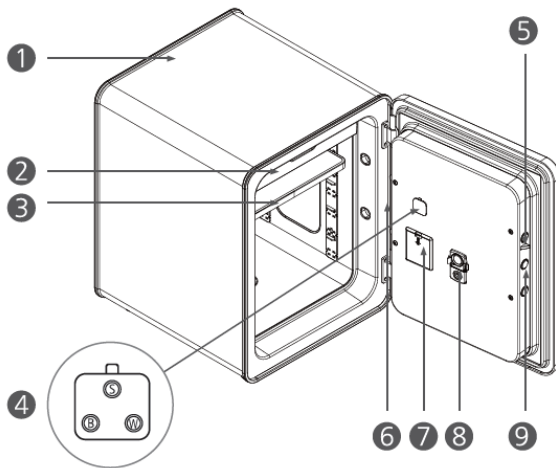

1. Main body
2. Pull-out drawer
3. Shelf (MC-40 only)
4. "S" Memory button
"B" (Not in use)
"W" (Not in use)
5. Door sensor
6. LED light
7. Battery case
8. Alarm
9. Lock bolt

Keypad overview

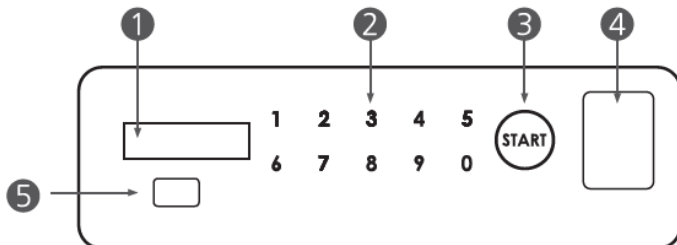

1. LCD Display
2. Touch keypad
3. START button
4. Fingerprint lock
5. USB-C port

Opening the safe

Press "START"



Enter passcode
Initial code: 123456



Press "START"



Pull the door

Changing the passcode

When using 2 user codes:



A: User 1

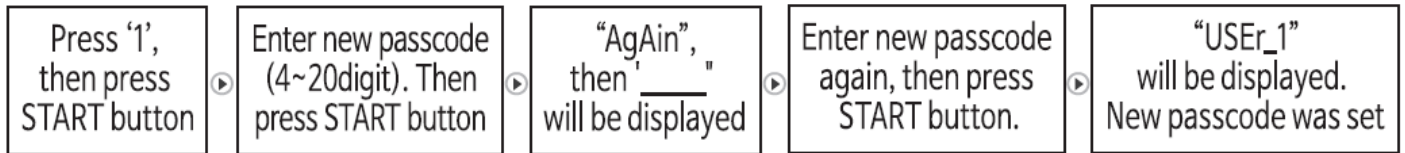

B: User 2

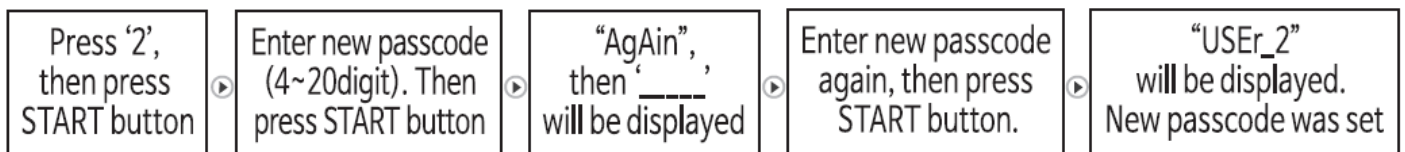

When using 1 user code:

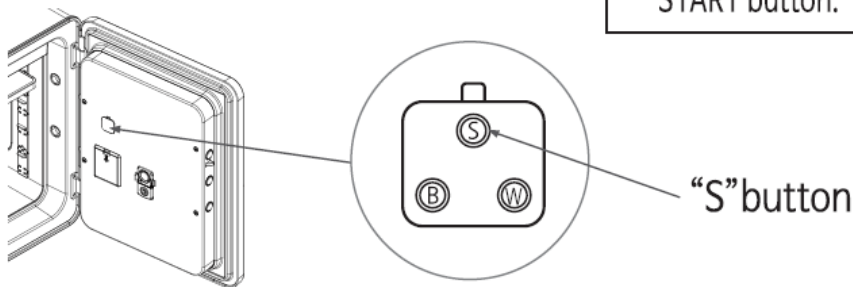
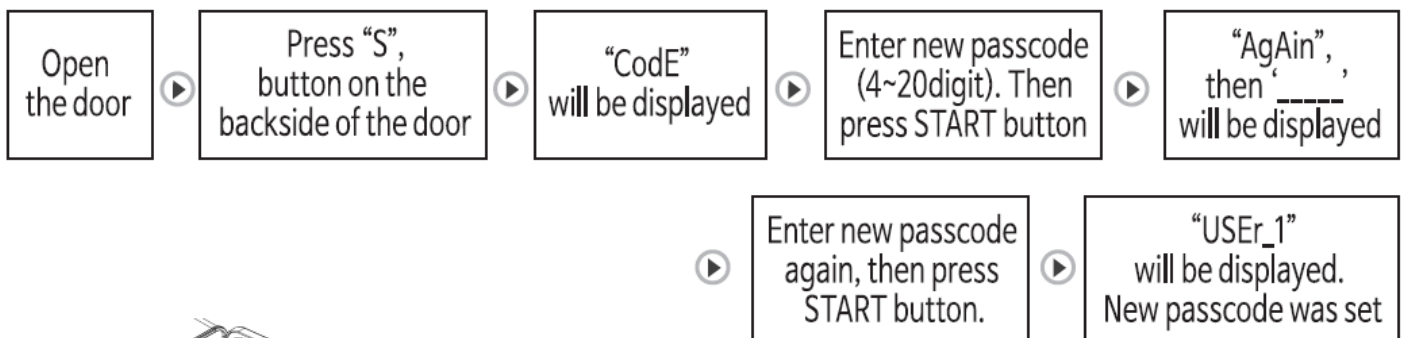

Register fingerprint (max. 10 fingerprints possible)



Deleting fingerprint



Replace batteries immediately when:

- Screen displays “Lo_bAt.”
- Safe door fails to open when “OPEn” message appears after passcode is entered.
- “good” appears on display along with “beep beep” sound after passcode is entered.
- screen fails to turn on after you press “START” button.
- touch button is not clear enough.
- there is no response or malfunction.

Micro USB `C` type port

In case the internal batteries are used up, you can use the micro USB-C port to give enough power to the lock to open the door.

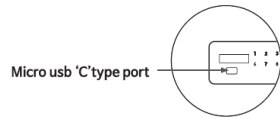

Keypad lock mode

1. Activate

Press “START” for more than 10 seconds until “Act” appears.

“Act” message signifies activation of keypad lock mode.

Any keypad input will only display “ACT”.



2. Deactivate

To deactivate keypad lock mode, press “START” for more than 3 seconds until “dEAct” appears.



How do I replace the batteries?

1. Open the safe door.
2. Open the battery compartment. You will find this compartment on the inside of the door (position 7 on the drawing on page 1 of this manual).
3. Replace the batteries. Use 1.5V alkaline batteries (AA x4).
4. Proper insertion of the batteries is confirmed once screen displays “good” message and a beep is heard.

Emergency code (E-Code)

Since the safe is not for IOT, emergency code will not transmit any messages to a 3rd party. If you unintentionally register the emergency code (E-CODE), please make sure it is the same as your passcode to avoid any confusion. Pressing the “S” button shortly twice will lead to the E-CODE registering mode.



Security mode

Press the “START” button twice to hide the passcode on the display.



Passcode displayed



Passcode not displayed

How to use the alarm

1. Use the “ON/OFF” switch on the alarm to control the alarm.
2. Use 3 x 1.5V AAA batteries.

When there is external impact or the safe is tilted, the alarm will go off (120dB sound). After 10 seconds from turning on the switch, the alarm is ready to operate. There is a light detecting sensor connected to the alarm. The alarm will be off when you open the door.

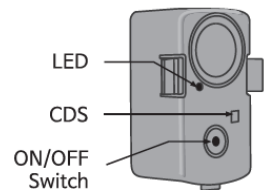

Volume control



Volume displayed

Emergency key

- Note:** 1. The emergency key is used to temporarily open the safe door in case the safe is inoperable. It is recommended not to use the master key in general usage of the safe.
2. The emergency key is a security device that can open the safe without entering a registered passcode. It is notified that the customer is responsible for the loss or theft of the emergency key. Please do not put the emergency key in the safe, but keep the keys in a different secure place.

How to open the safe with the emergency key

1. Remove a square-shaped cover by pulling out the small hole on it. Clip or needle can be used. The square-shaped cover is on the front left side of the safe. Pull it out completely using a ball pen or a clip.

2. Insert the emergency key into the hole. Place the emergency key groove direction upward and insert it all the way into the hole. Pay attention to the direction of the groove and check if it is completely inserted.

3. Unlock the emergency key by rotating it 120 degrees clockwise. If the emergency key groove direction is 120 degrees downward, the door can be opened.

Caution: when rotating the emergency key, do not forcefully turn it, please turn it slowly. There is a risk of damage if the emergency key is turned excessively.

4. To use the door as usual after opening the door using the emergency key:

- Rotate the emergency key 120 degrees counterclockwise.
 - Remove the emergency key and put the cover again.
- When an Err-05 message is displayed, enter the correct passcode or fingerprint to settle the error message.

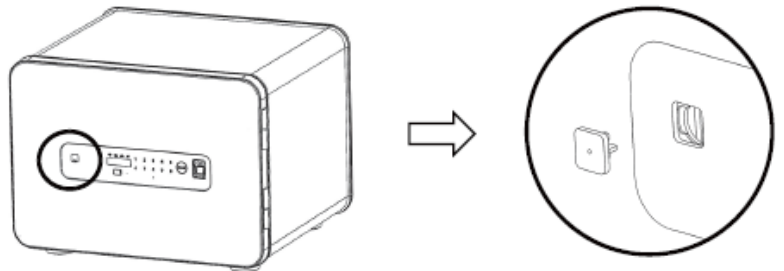

Location of the emergency key hole

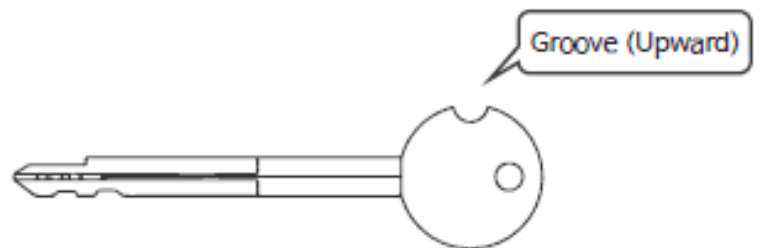

Position of the key

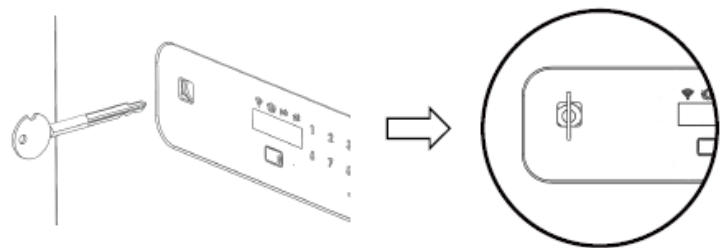

Placing emergency key in key hole

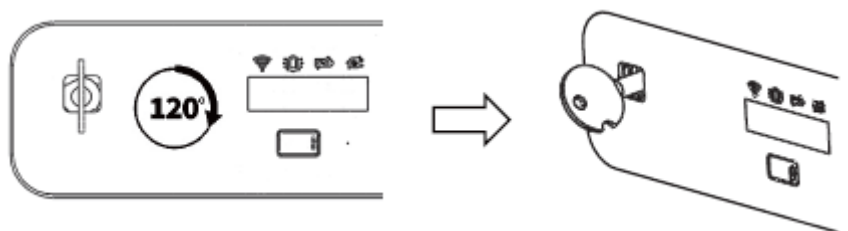

Turning the emergency key clockwise

Trouble shooting

Situation	Possible Cause	Measures
No response when START button pressed	<ul style="list-style-type: none"> · Battery discharge · Incorrect insertion of batteries · Keypad Lock mode ON · Circuit error 	<ul style="list-style-type: none"> · Replace batteries with new ones. · Confirm correct insertion of batteries. · Press START for 3 seconds to deactivate Keypad Lock mode. · Contact store where safe was purchased.
Alarm continues ringing and safe does not work	<ul style="list-style-type: none"> · 5 times wrong passcode input 	<ul style="list-style-type: none"> · Enter correct passcode or wait for 3 minutes until alarm stops.
“Err-03” message appears	<ul style="list-style-type: none"> · Incorrect passcode 	<ul style="list-style-type: none"> · Enter correct passcode.
Cannot change passcode	<ul style="list-style-type: none"> · Exceed time limit when changes passcode · Keypad malfunction · Button error 	<ul style="list-style-type: none"> · Enter passcode within 5 seconds. · Contact store where safe was purchased.
“Lo_bAt” message appears	<ul style="list-style-type: none"> · Low battery 	<ul style="list-style-type: none"> · Replace batteries with new ones.
“Act” message appears	<ul style="list-style-type: none"> · Keypad Lock mode ON 	<ul style="list-style-type: none"> · Press START button for 3 seconds to deactivate Keypad Lock mode
Forgot passcode		<ul style="list-style-type: none"> · Contact store where safe was purchased.

De Raat Security Products BV

Edelgasstraat 5
2718 SX Zoetermeer
Nederland
+31 (0) 79 361 52 36
verkoop@deraat.nl
www.deraat.eu

De Raat Security Products NV

Gareelmakersstraat 10
2200 Herentals
België
+32 (0) 14 232371
info@deraat.be
www.deraat.eu

De Raat Security Products Ltd.

Unit 32 Axis Park
Manasty Road
Orton Southgate
Peterborough, PE2 6UP
United Kingdom
+44 (0) 0330 058 5306
sales@deraat.co.uk
www.deraat.co.uk