

Aspire locks with a touch RFID interface are operated by an RFID credential or by an ADA compliant User Key. Manager credentials (Manager Key or RFID) provide management access and/or external power. Programming is accomplished via a Programming Key unique to the lock system. An optional mobile application tool simplifies lock system management and provides audit trail.

Lock Parts

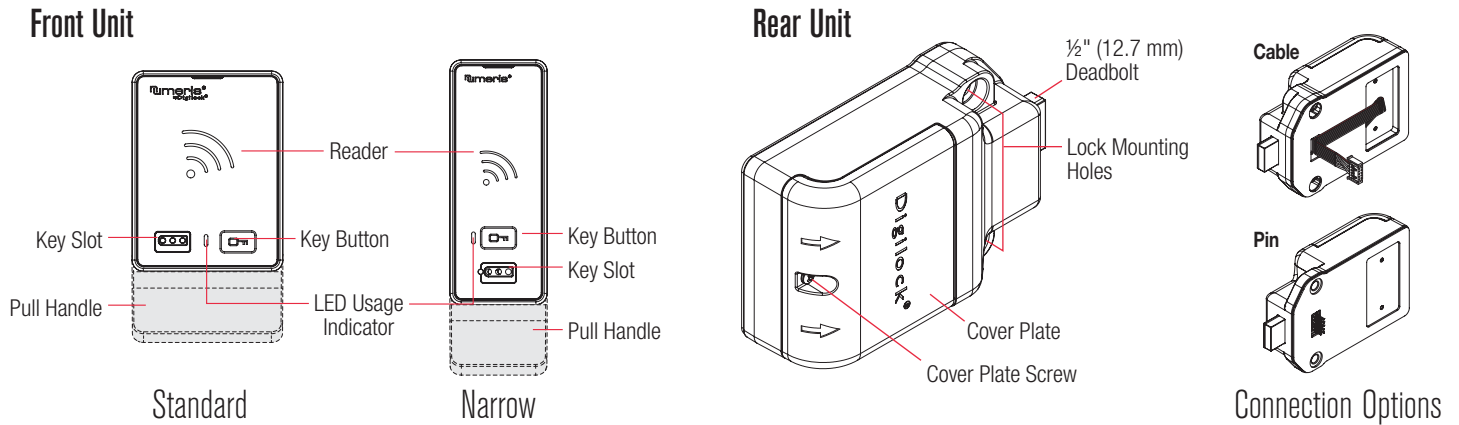

RFID Credentials

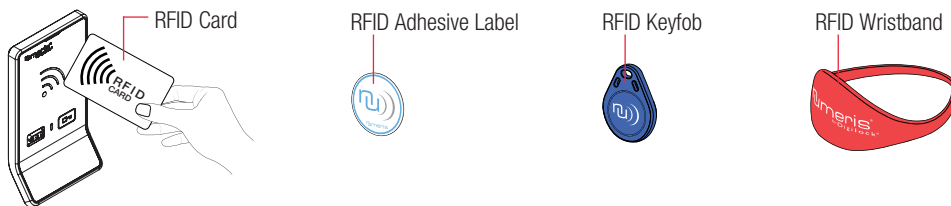

Keys

	User Key	Manager Key ¹	Programming Key ²
Operates the lock	•	•	•
Overrides user access		•	•
Allows management inspection		•	•
Provides external power		•	•
Programs manager credentials to the lock			•

¹ Up to 6 manager credentials (Manager Key or RFID) may be programmed to each lock. If managed with the optional Mobile App, up to 250 manager credentials may be programmed to each lock.

² 1 Programming Key allowed per lock system.

Key Insertion

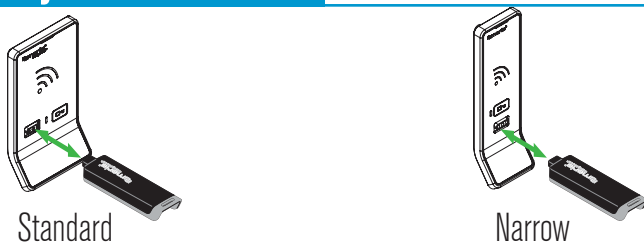

Numeris logo must face up on standard and narrow body locks.

Setup

Locks are shipped with factory default settings (only operates by pressing ) . Each lock must be setup to operate with a Programming Key and manager credentials (Manager Key or RFID).

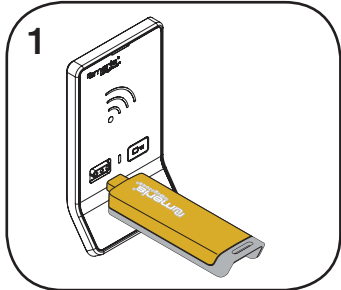

1
Insert the Programming Key.
A two-tone beep will be heard and the LED and Reader will turn on.

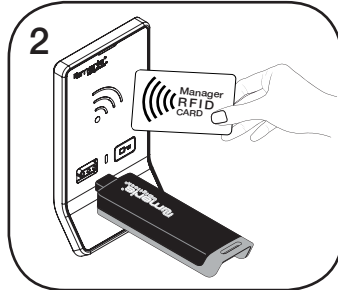

2
Insert one Manager Key or present one Manager RFID at a time.
A two-tone beep will be heard for each manager credential programmed.

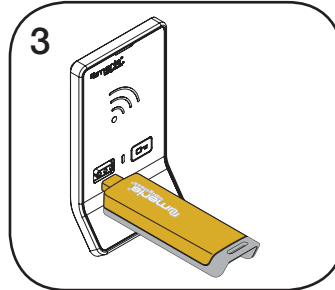

3
Insert the Programming Key.
A two-tone beep will be heard and the LED and Reader will turn off.

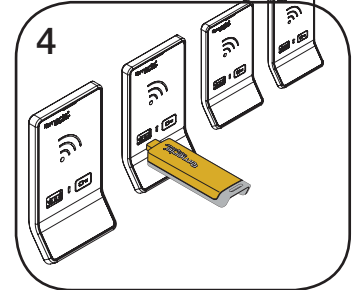

4
Repeat above steps for each lock or follow instructions to [Express Register Manager Credentials](#) to setup all the locks.

Programming Instructions

Express Register Manager Credentials

The Programming Key can quickly program multiple locks to operate with the same manager credentials.

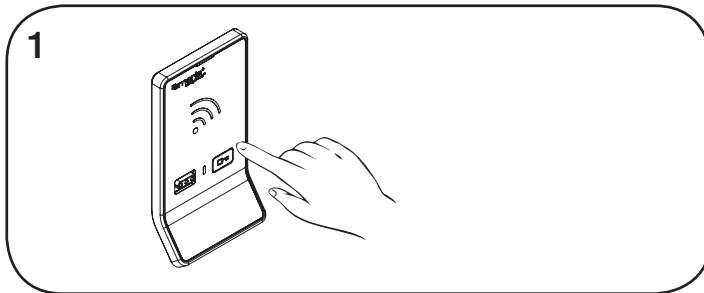

1
Go to a lock already programmed to operate with the manager credentials.

Touch and hold  for 10 seconds (a two-tone beep will be heard after 5 seconds followed by 2 sets of two-tone beeps after 10 seconds) then release. The LED will flash.

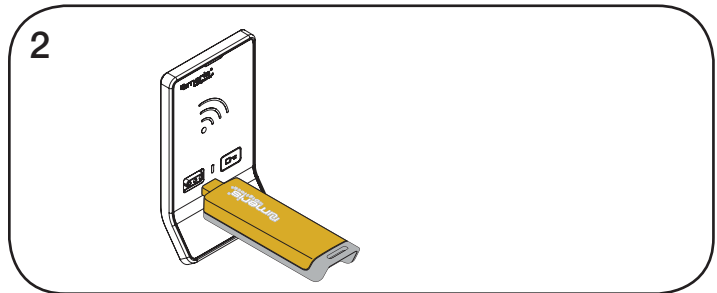

2
Insert the Programming Key.
Two sets of two-tone beeps will be heard and the LED will turn off.

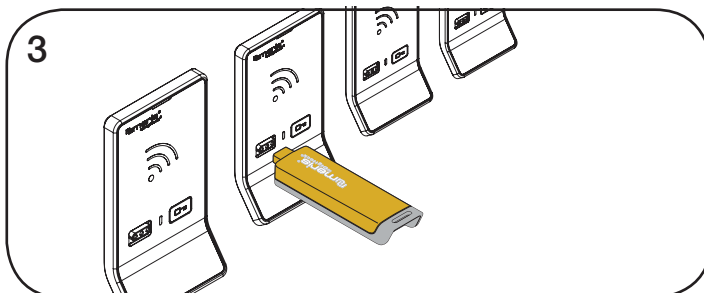

3
Insert the Programming Key to program each lock to operate with the same manager credentials.

Two sets of two-tone beeps will be heard and the LED will flash once to indicate successful programming.

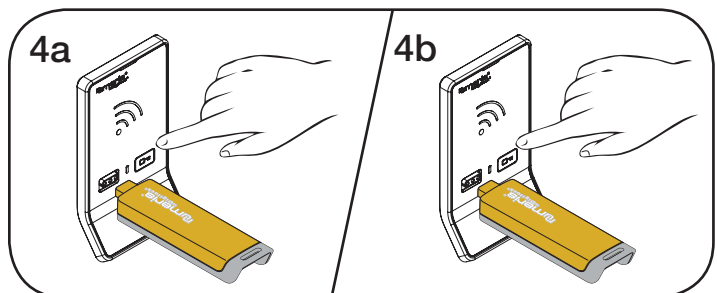

4a
End express registration mode.*

Go to any programmed lock.

Touch  then insert the Programming Key.

Touch  then insert the Programming Key again to return the bolt to the original position.

*The Programming Key will continue to function in express registration mode until it is used to operate a lock.

Setup

Add Manager Credentials

Manager credentials can be programmed to the locks at any time.

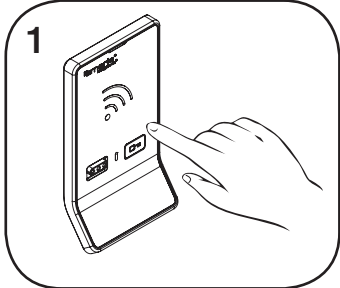

Go to a lock requiring additional manager credentials.

Touch and hold  for 5 seconds (a two-tone beep will be heard after 5 seconds) then release.

The LED will flash and the Reader will turn on.

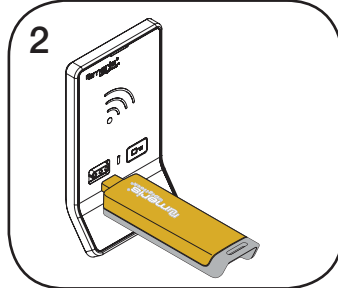

Insert the Programming Key.
A two-tone beep will be heard.

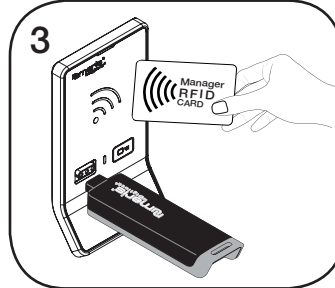

Insert each additional Manager Key or present each Manager RFID one at a time.

A two-tone beep will be heard for each manager credential programmed.

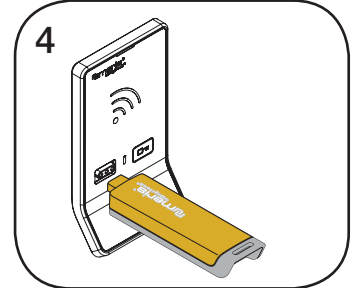

Insert the Programming Key.
A two-tone beep will be heard and the LED and Reader will turn off.

Repeat above steps for each lock or follow instructions to [Express Register Manager Credentials](#) to quickly program the same manager credentials to operate multiple locks.

Replace Programming Key or Manager Credentials

The locks must be reprogrammed to prevent the lost/stolen Programming Key or manager credentials from operating a lock.

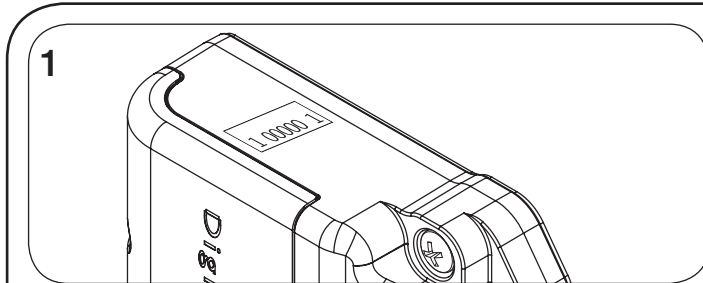

To replace the Programming Key:

Note the order or serial number (found on the lock's rear unit).



Contact Digilock Support to purchase a replacement Programming Key.

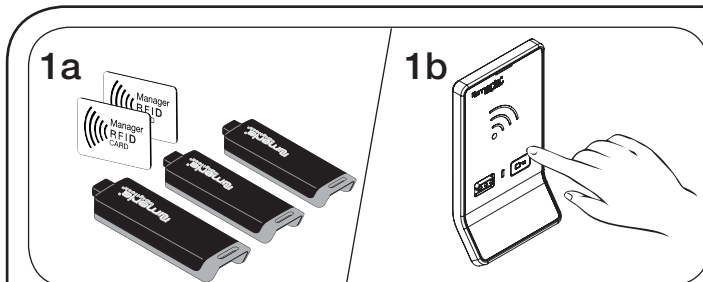

To replace Manager Credentials:

Collect all remaining and replacement manager credentials.

Go to any lock operated by the lost/stolen manager credentials.

Touch and hold  for 5 seconds (a two-tone beep will be heard after 5 seconds) then release.

The LED will flash and the Reader will turn on.

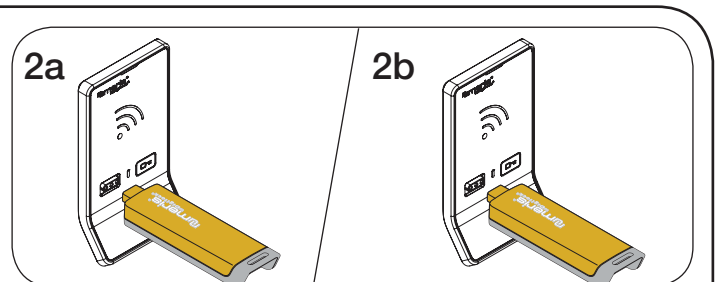

Insert the Programming Key.

A two-tone beep will be heard.

Insert the Programming Key again.

Three sets of two-tone beeps will be heard and the LED and Reader will turn off. All previously programmed manager credentials will be erased.

Follow instructions to [Add Manager Credentials](#) to program the remaining and replacement manager credentials to the locks.

Operating Instructions - In Shared Use Functionality

In shared use functionality, the user presents an RFID or inserts any User Key to lock and the same RFID or User Key to unlock. Once unlocked, the lock is available for a different user.

1a

1b

Operate with an RFID

To lock: Touch then present an RFID.

To unlock: Touch then present the same RFID.

1a

1b

Operate with a User Key

To lock: Insert any User Key.

To unlock: Insert the same User Key.

1a

1b

Operate with a Manager Credential

To unlock: Insert a valid Manager Key or touch then present a valid Manager RFID.

To relock: Insert a valid Manager Key or touch then present a valid Manager RFID.*

1a

1b

Operate with the Programming Key

To unlock: Touch then insert the Programming Key.

To relock: Touch then insert the Programming Key.*

*If a manager credential or the Programming Key is used to relock, the previous user credential will continue to operate the lock.

Support

Error Condition Indicators

10 rapid beeps:

The lock is binding which means that either door alignment or stored items are preventing the lock from operating. Press on the door while operating the lock. If error condition persists, contact Digilock support for assistance.

2 sets of three beeps:

The batteries are low. Replace the batteries.

Does not Unlock with the User Credential (User Key or RFID)

The lock does not recognize the user credential. For immediate access, operate with a valid manager credential.

Does not Operate with a Manager Credential (Manager Key or RFID)

The lock does not recognize the manager credential. Follow instructions to [Add Manager Credentials](#) to program the manager credential to the lock. For immediate access, operate with another valid manager credential or with the Programming Key.

Does not Operate with the Programming Key

The lock does not recognize the Programming Key. If the Programming Key has been replaced, operate with the Replacement Programming Key. Contact Digilock support for additional assistance.

No Audible Feedback when is Pressed

- The batteries may need to be replaced. For immediate access, operate with a valid Manager Key.
- The front unit may not be properly connected to the rear unit. Remove the lock from the door and check the connection.

Battery Replacement

It is not necessary to remove the lock from the door. In case of battery failure, operate with a valid Manager Key.

CAUTION: Risk of explosion or leakage if battery is replaced by an incorrect type, mixed with a different battery type, or inserted backwards. Replace all batteries of a set at the same time. Be sure to insert batteries with correct polarities. Remove exhausted batteries from product promptly and dispose of used batteries according to the battery manufacturer's instructions.

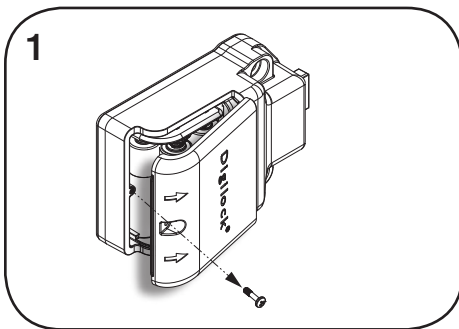

1 Remove the screw from the Cover Plate with a Phillips head screwdriver.

Remove the Cover Plate by lifting the tab at the edge of the cover, below the arrows.

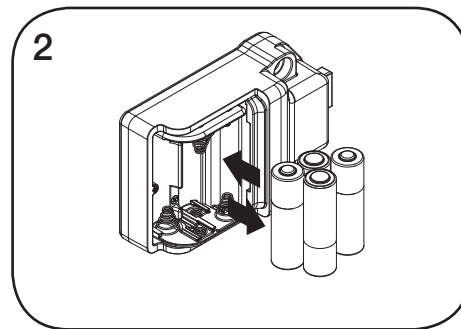

2 Remove the batteries from the housing.

Replace with four premium alkaline AA batteries. Dispose or recycle used batteries according to local regulations.

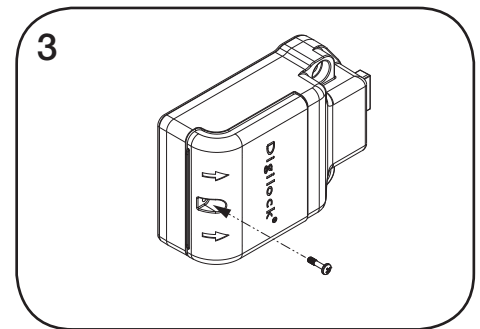

3 Replace the Cover Plate and secure with the screw.